

APPLICATION NOTE

Artasie AMX8X5 Counter Loss

Ultra-low power coupled with a highly sophisticated feature set

A-RTCX85-ANGA03EN v2.0



Legal Information and Disclaimers

AMBIQ MICRO INTENDS FOR THE CONTENT CONTAINED IN THE DOCUMENT TO BE ACCURATE AND RELIABLE. THIS CONTENT MAY, HOWEVER, CONTAIN TECHNICAL INACCURACIES, TYPOGRAPHICAL ERRORS OR OTHER MISTAKES. AMBIQ MICRO MAY MAKE CORRECTIONS OR OTHER CHANGES TO THIS CONTENT AT ANY TIME. AMBIQ MICRO AND ITS SUPPLIERS RESERVE THE RIGHT TO MAKE CORRECTIONS, MODIFICATIONS, ENHANCEMENTS, IMPROVEMENTS AND OTHER CHANGES TO ITS PRODUCTS, PROGRAMS AND SERVICES AT ANY TIME OR TO DISCONTINUE ANY PRODUCTS, PROGRAMS, OR SERVICES WITHOUT NOTICE.

THE CONTENT IN THIS DOCUMENT IS PROVIDED "AS IS". AMBIQ MICRO AND ITS RESPECTIVE SUPPLIERS MAKE NO REPRESENTATIONS ABOUT THE SUITABILITY OF THIS CONTENT FOR ANY PURPOSE AND DISCLAIM ALL WARRANTIES AND CONDITIONS WITH REGARD TO THIS CONTENT, INCLUDING BUT NOT LIMITED TO, ALL IMPLIED WARRANTIES AND CONDITIONS OF MERCHANTABILITY, FITNESS FOR A PARTICULAR PURPOSE, TITLE AND NON-INFRINGEMENT OF ANY THIRD PARTY INTELLECTUAL PROPERTY RIGHT.

AMBIQ MICRO DOES NOT WARRANT OR REPRESENT THAT ANY LICENSE, EITHER EXPRESS OR IMPLIED, IS GRANTED UNDER ANY PATENT RIGHT, COPYRIGHT, MASK WORK RIGHT, OR OTHER INTELLECTUAL PROPERTY RIGHT OF AMBIQ MICRO COVERING OR RELATING TO THIS CONTENT OR ANY COMBINATION, MACHINE, OR PROCESS TO WHICH THIS CONTENT RELATE OR WITH WHICH THIS CONTENT MAY BE USED.

USE OF THE INFORMATION IN THIS DOCUMENT MAY REQUIRE A LICENSE FROM A THIRD PARTY UNDER THE PATENTS OR OTHER INTELLECTUAL PROPERTY OF THAT THIRD PARTY, OR A LICENSE FROM AMBIQ MICRO UNDER THE PATENTS OR OTHER INTELLECTUAL PROPERTY OF AMBIQ MICRO.

INFORMATION IN THIS DOCUMENT IS PROVIDED SOLELY TO ENABLE SYSTEM AND SOFTWARE IMPLEMENTERS TO USE AMBIQ MICRO PRODUCTS. THERE ARE NO EXPRESS OR IMPLIED COPYRIGHT LICENSES GRANTED HEREUNDER TO DESIGN OR FABRICATE ANY INTEGRATED CIRCUITS OR INTEGRATED CIRCUITS BASED ON THE INFORMATION IN THIS DOCUMENT. AMBIQ MICRO RESERVES THE RIGHT TO MAKE CHANGES WITHOUT FURTHER NOTICE TO ANY PRODUCTS HEREIN. AMBIQ MICRO MAKES NO WARRANTY, REPRESENTATION OR GUARANTEE REGARDING THE SUITABILITY OF ITS PRODUCTS FOR ANY PARTICULAR PURPOSE, NOR DOES AMBIQ MICRO ASSUME ANY LIABILITY ARISING OUT OF THE APPLICATION OR USE OF ANY PRODUCT OR CIRCUIT, AND SPECIFICALLY DISCLAIMS ANY AND ALL LIABILITY, INCLUDING WITHOUT LIMITATION CONSEQUENTIAL OR INCIDENTAL DAMAGES. "TYPICAL" PARAMETERS WHICH MAY BE PROVIDED IN AMBIQ MICRO DATA SHEETS AND/OR SPECIFICATIONS CAN AND DO VARY IN DIFFERENT APPLICATIONS AND ACTUAL PERFORMANCE MAY VARY OVER TIME. ALL OPERATING PARAMETERS, INCLUDING "TYPICALS" MUST BE VALIDATED FOR EACH CUSTOMER APPLICATION BY CUSTOMER'S TECHNICAL EXPERTS. AMBIQ MICRO DOES NOT CONVEY ANY LICENSE UNDER NEITHER ITS PATENT RIGHTS NOR THE RIGHTS OF OTHERS. AMBIQ MICRO PRODUCTS ARE NOT DESIGNED, INTENDED, OR AUTHORIZED FOR USE AS COMPONENTS IN SYSTEMS INTENDED FOR SURGICAL IMPLANT INTO THE BODY, OR OTHER APPLICATIONS INTENDED TO SUPPORT OR SUSTAIN LIFE, OR FOR ANY OTHER APPLICATION IN WHICH THE FAILURE OF THE AMBIQ MICRO PRODUCT COULD CREATE A SITUATION WHERE PERSONAL INJURY OR DEATH MAY OCCUR. SHOULD BUYER PURCHASE OR USE AMBIQ MICRO PRODUCTS FOR ANY SUCH UNINTENDED OR UNAUTHORIZED APPLICATION, BUYER SHALL INDEMNIFY AND HOLD AMBIQ MICRO AND ITS OFFICERS, EMPLOYEES, SUBSIDIARIES, AFFILIATES, AND DISTRIBUTORS HARMLESS AGAINST ALL CLAIMS, COSTS, DAMAGES, AND EXPENSES, AND REASONABLE ATTORNEY FEES ARISING OUT OF, DIRECTLY OR INDIRECTLY, ANY CLAIM OF PERSONAL INJURY OR DEATH ASSOCIATED WITH SUCH UNINTENDED OR UNAUTHORIZED USE, EVEN IF SUCH CLAIM ALLEGES THAT AMBIQ MICRO WAS NEGLIGENT REGARDING THE DESIGN OR MANUFACTURE OF THE PART.

Revision History

| Revision | Date | Description |
|----------|------------------|---------------------------|
| 1.0 | February 2017 | Initial Release. |
| 2.0 | January 18, 2023 | Updated document template |

Reference Documents

| Document ID | Description |
|-------------|-------------|
| | |
| | |

Table of Contents

- 1. Introduction 7**
- 2. Measurement Methodology 8**
- 3. Loss vs I2C Frequency Results 9**
 - 3.1 I2C Freq 10
 - 3.2 Refs Per Sec 10
 - 3.3 Bursts 10
 - 3.4 Total Time 10
 - 3.5 Error 10
 - 3.6 Error @ 100 Refs/Second 10
 - 3.7 Error Cycles 10
 - 3.8 EC Per Million 11
 - 3.9 Time Error 11
 - 3.10 Time Error Per Cycle 11
- 4. Error Mechanism Details 12**
- 5. Conclusions 15**
- 6. Delay Between Read Address and Data 17**

List of Tables

| | |
|---|----|
| Table 3-1 I2C Frequency Variation Data | 9 |
| Table 4-1 Sync Error Probability | 13 |
| Table 4-2 Maximum Bus Frequency | 14 |
| Table 5-1 Error Summary | 15 |
| Table 5-2 Maximum Burst Rates | 16 |
| Table 5-3 Burst Read Power Requirements | 16 |

List of Figures

Figure 2-1 Measurement System 8
Figure 4-1 Synchronization Circuit 12
Figure 4-2 Synchronization Race Error 13
Figure 6-1 Read Transactions Delay 17

SECTION

1

Introduction

Under certain rare circumstances, the combination of low I²C clock frequencies and very frequent burst read references to the AMX8XX Calendar counters can cause a small time loss from the Calendar counters. This document describes experiments which quantify the possible loss.

SECTION

2

Measurement Methodology

Because the time losses are very small, measuring them accurately is challenging. Ambiq has created a measurement system to specifically address the issue of measuring these small changes over long time periods, which is typically not feasible with commercial frequency counters. The system is shown in Figure 2-1.

Figure 2-1: Measurement System

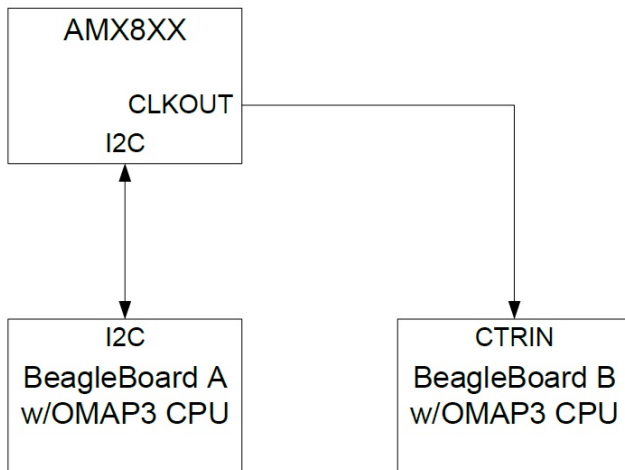

The BeagleBoard is a commercially available processing system built around a Texas Instruments OMAP3 high performance processor. Two BeagleBoards are used in the measurement system, and each has been modified to use a 26 MHz TCXO to provide the fundamental input clock for high accuracy. BeagleBoard A is used to control the AMX8XX via the I²C interface (the SPI interface may also be used). The AMX8XX is configured to drive a clock onto the CLKOUT pin, typically the 1 second clock which drives the Calendar counters. The CLKOUT pin is connected to a counter/timer input CTRIN of BeagleBoard B, and software on this BeagleBoard allows the length of each clock period to be captured with a precision of ± 40 ns and stored in local memory. This data is then extracted and extensive data analysis is performed. Up to 250,000 clock cycles may be captured (almost 3 days if seconds are captured), allowing very precise measurements over very long time periods.

SECTION

3

Loss vs I²C Frequency Results

A set of experiments modified the I²C frequency while performing burst reads of the Counter Registers (offsets 0 to 7) with no gaps between bursts. Table 3-1 contains the results of a series of runs with I²C frequencies from 10000 Hz to 100000 Hz (10 kHz to 100 kHz). Each column will be explained below. Note that all of these runs were performed with typical silicon at 25°C.

Table 3-1: I²C Frequency Variation Data

| I ² C Freq (Hz) | Ref Per Sec | Bursts | Total Time (s) | Error (ppm) | Error @ 100 Refs/second (ppm) | Error Cycles | EC Per Million | Time Error (ms) | Time Error per Cycle (ms) |
|----------------------------|-------------|----------|----------------|-------------|-------------------------------|--------------|----------------|-----------------|---------------------------|
| 10000 | 95.45 | 2100000 | 22000.65 | 28.61 | 29.97 | 44 | 20.95 | 629.455 | 14.306 |
| 11000 | 105.16 | 2200000 | 20920.9 | 35.39 | 33.65 | 71 | 32.27 | 740.341 | 10.427 |
| 12000 | 114.55 | 2000000 | 17460 | 26.99 | 23.56 | 36 | 18.00 | 471.255 | 13.090 |
| 15000 | 142.78 | 2000000 | 14007.8 | 23.89 | 16.74 | 34 | 17.00 | 334.703 | 9.844 |
| 20000 | 189.87 | 3000000 | 15800.1 | 23.83 | 12.55 | 39 | 13.00 | 376.445 | 9.652 |
| 25000 | 236.60 | 4000000 | 16906 | 27.81 | 11.75 | 47 | 11.75 | 470.088 | 10.002 |
| 30000 | 284.94 | 4000000 | 14038 | 24.92 | 8.75 | 35 | 8.75 | 349.807 | 9.994 |
| 35000 | 331.10 | 4000000 | 12081 | 15.89 | 4.80 | 19 | 4.75 | 191.988 | 10.105 |
| 40000 | 376.44 | 4000000 | 10626 | 21.50 | 5.71 | 23 | 5.75 | 228.429 | 9.932 |
| 45000 | 420.92 | 6000000 | 14254.5 | 18.19 | 4.32 | 26 | 4.33 | 259.261 | 9.972 |
| 50000 | 468.11 | 6000000 | 12817.5 | 23.13 | 4.94 | 30 | 5.00 | 296.283 | 9.876 |
| 75000 | 689.27 | 13775000 | 19985 | 15.20 | 2.21 | 31 | 2.25 | 303.856 | 9.802 |
| 100000 | 941.97 | 12000000 | 12739.2 | 0.00 | 0.00 | 0 | 0.00 | 0.000 | 0 |

3.1 I²C Freq

This is the frequency of the I²C bus in Hz.

3.2 Refs Per Sec

This is the number of burst reads per second which are performed when 8-byte bursts are executed with no delay between them. This is the maximum possible burst frequency for each I²C clock frequency.

3.3 Bursts

This is the total number of read bursts executed in the run.

3.4 Total Time

This is the time in seconds which the entire run took. This time is between 3 and 6 hours for each experiment.

3.5 Error

This is the deviation in parts per million (ppm) of the time measured in the Counters as compared to the correct time as measured by the precise BeagleBoard clock.

3.6 Error @ 100 Refs/Second

Under the assumption that an error has equal probability on each burst read, this is the time difference in ppm normalized to 100 burst reads per second.

3.7 Error Cycles

For each run, the pattern of one second period lengths shows that only a few cycles contain errors. This column contains the number of such cycles in each run.

3.8 EC Per Million

This is the number of error cycles per million overall cycles, which normalizes the error cycle numbers.

3.9 Time Error

This is the overall time deviation which occurred during the run in milliseconds.

3.10 Time Error Per Cycle

This is the time deviation created by each error cycle in milliseconds. Note that this error is always very close to 10 ms, which shows that the problem is caused by a synchronization between the I²C clock and the 100 Hz clock which drives the Calendar counter chain. This also indicates that the maximum time deviation for any single burst reference will be no more than 10 ms at bus frequencies above 12 kHz.

SECTION

4

Error Mechanism Details

The physical experiments described above identified clock synchronization as the likely cause of the time loss. At that point, chip simulations were run to isolate the exact problem. The clock loss occurs due to a synchronization error between a burst read request clocked by the I²C/SPI clock and the 2 kHz clock from the counter timing chain. The 2 kHz clock is divided by 20.48 to create the 100 Hz timing clock, and the 2 kHz clock also clocks a number of flip flops which are used to hold off the 100 Hz clock when a read to the Calendar Counters is occurring, in order to insure that the values read from all of the Counters is consistent (e.g., no counter rolls over during the read).

The circuit in Figure 4-1 is used to generate a version of the read request synchronized to the negative edge of the 2 kHz clock clk2K_n (the rising edge of clk2K_n). When read_req is asserted, under normal circumstances the output nreq is set on the next edge of clk2K_n, and the delayed version of the request del is asserted on that edge so that nreq is asserted for one cycle.

Figure 4-1: Synchronization Circuit

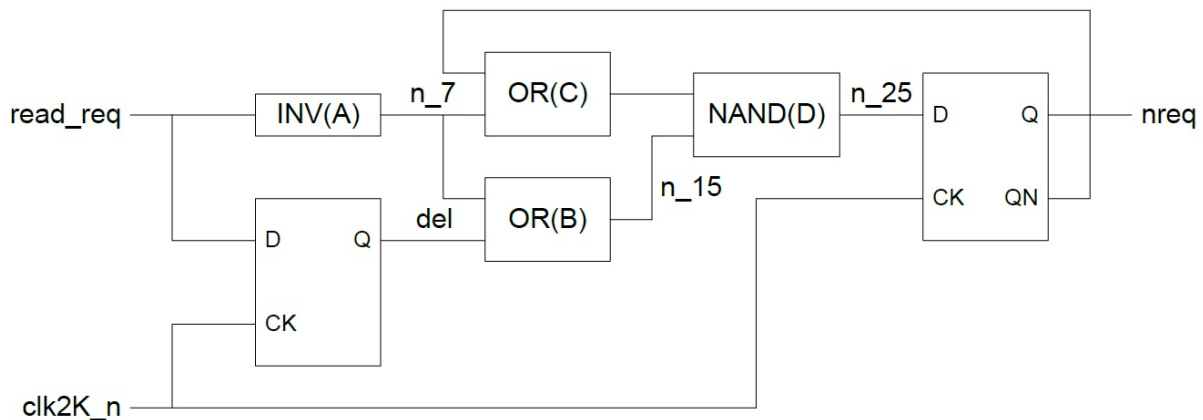

However, this circuit contains a race as shown in the timing diagram of Figure 4-2. If the edge of clk2K_n occurs just after the edge of read_req, the del flop will capture the read_req, but the delays in gates A, B, C and D will cause n_25 to be asserted too late and the nreq flop will not be asserted. The del flop will then remove n_15 and n_25 so that nreq never goes high. This condition is referred to as a “sync error”.

Figure 4-2: Synchronization Race Error

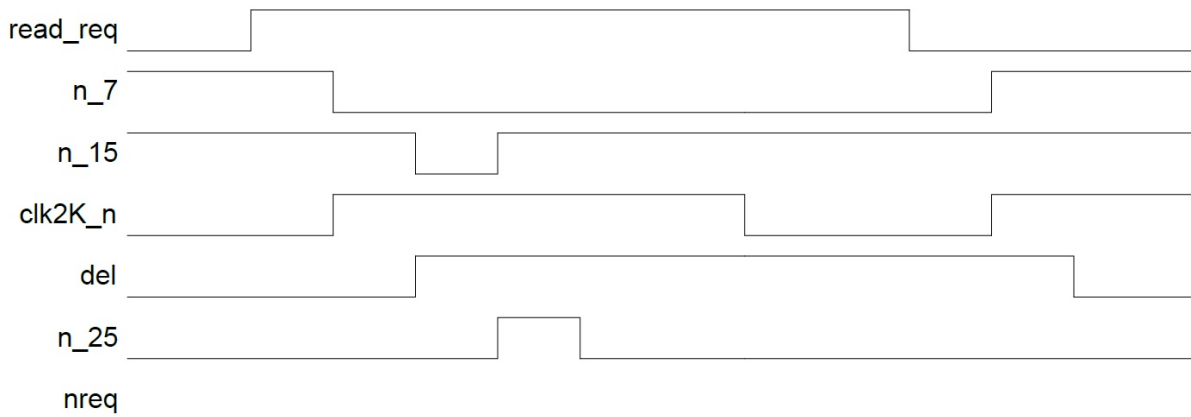

The window in which this error can occur is essentially the delays through the gates A, B, C and D (in the actual design C and D are part of the same OAI gate). For the worst case (at -40 °C) this delay is on the order of 1520 ns. Since the period of clk2K_n is 488 us, any particular reference can produce an error (a lost nreq) with a probability of $(1520/488281) = 0.0031 = 0.31\%$. This probability (probsync) drops significantly as the temperature increases, as shown in Table 4-1 (all values are for worst case slow silicon). This occurs because the delay drops significantly at slightly higher temperatures.

Table 4-1: Sync Error Probability

| Temperature | probsync |
|-------------|----------|
| -40°C | 0.31% |
| -25°C | 0.07% |
| 25°C | 0.025% |

A sync error can cause the actual loss of a 100 Hz clock only if it occurs during the cycle in which the 100 Hz generation logic would produce a clock cycle (the 100 Hz clock is typically asserted for one period of clk2K). Because nreq is not asserted, logic which normally delays the clock pulse until the read is complete is not active, so the clock is gated by the read and lost. The probability of a clock loss due to a sync error is a function of the length of the AMX8XX internal read request. The length of the read request is a function of the I²C clock period and the number of Counters which are read in the burst, defined by:

$$\text{length} = I^2C \text{ clock period} \times (\# \text{ of bytes read} \times 9)$$

The probability that a sync error will cause the loss of a 100 Hz clock (prob100) is roughly:

$$\text{prob100} = 0.1 * (\text{length in ms} - 0.850)$$

If length is less than 0.85 ms, no errors can occur (prob100 = 0). For each burst length, this defines a minimum I²C clock frequency above which correct operation is guaranteed, as shown in Table 4-2.

Table 4-2: Maximum Bus Frequency

| Length (B) | I ² C Period (μs) | I ² C Frequency (kHz) |
|------------|------------------------------|----------------------------------|
| 1 | 94.444 | 10.59 |
| 2 | 47.222 | 21.18 |
| 3 | 31.481 | 31.76 |
| 4 | 23.611 | 42.35 |
| 5 | 18.889 | 52.94 |
| 6 | 15.741 | 63.53 |
| 7 | 13.492 | 74.12 |
| 8 | 11.806 | 84.71 |

In order to verify the minimum frequency assertion, an AMX8XX slow corner silicon part was run at 83.33 kHz at -40 °C for 12 hours at the maximum 8-byte burst rate, which included 30,000,000 burst reads. No errors occurred during this test.

SECTION

5

Conclusions

For a single burst read, the probability that a 100 Hz clock cycle will be lost (problast) is given by:

$$\text{problast} = \text{probsync} * \text{prob100}$$

Table 5-1 shows the error rate and the absolute error in milliseconds/day for several I²C clock frequencies and burst frequencies, assuming that the specified burst frequency occurs continuously and the system is at -40 °C. Note that for burst rates below 1 per second, the error is expressed in parts per billion (ppb).

Table 5-1: Error Summary

| I ² C Freq (Hz) | Error Rate at Burst Frequency | | | | Milliseconds/Day at Burst Frequency | | | |
|----------------------------|-------------------------------|-------------|-------------|----------------|-------------------------------------|--------|-------|----------|
| | 10/sec (ppm) | 1/sec (ppm) | 1/min (ppb) | 1/15 min (ppb) | 10/sec | 1/sec | 1/min | 1/15 min |
| 10000 | 197.68 | 19.77 | 329.46 | 21.96 | 2287.79 | 228.79 | 3.813 | 0.254 |
| 20000 | 85.61 | 8.56 | 142.68 | 9.51 | 990.83 | 99.08 | 1.651 | 0.110 |
| 30000 | 48.25 | 4.83 | 80.42 | 5.36 | 558.47 | 55.85 | 0.931 | 0.062 |
| 40000 | 29.57 | 2.96 | 49.29 | 3.29 | 342.29 | 34.23 | 0.570 | 0.038 |
| 50000 | 18.37 | 1.84 | 30.61 | 2.04 | 212.58 | 21.26 | 0.354 | 0.024 |
| 60000 | 10.90 | 1.09 | 18.16 | 1.21 | 126.11 | 12.61 | 0.210 | 0.014 |
| 75000 | 5.56 | 0.56 | 9.26 | 0.62 | 64.34 | 6.43 | 0.107 | 0.007 |
| 85000 | 0 | 0 | 0 | 0 | 0 | 0 | 0 | 0 |

Based on the equations, for any particular I²C frequency a maximum burst frequency can be determined which is guaranteed to produce no more than a specified error. Since the AMX8XX XT Oscillator can only be calibrated to 2 ppm, an error of 2 ppm can reasonably be assumed to be negligible. Table 5-2 on page 16 below shows the maximum burst frequency for various error values and I²C frequencies. For example, if the I²C clock is 50 kHz, a burst rate less than 1.09 bursts/second will produce a maximum error less than 2 ppm.

Table 5-2: Maximum Burst Rates

| I ² C Freq (Hz) Max ppm -> | Maximum Bursts/Second | | |
|--|-----------------------|------|------|
| | 1 | 2 | 5 |
| 10000 | 0.05 | 0.10 | 0.25 |
| 20000 | 0.12 | 0.23 | 0.58 |
| 30000 | 0.21 | 0.41 | 1.04 |
| 40000 | 0.34 | 0.68 | 1.69 |
| 50000 | 0.54 | 1.09 | 2.72 |
| 60000 | 0.92 | 1.84 | 4.59 |
| 70000 | 1.80 | 3.60 | 8.99 |
| 85000 | N/A | N/A | N/A |

It is important to note that the above time losses are for continuous burst reads at the specified rate. Continuous high burst rates will require significant current to be drawn in the system, as shown in Table 5-3 for 8-byte burst reads from the Counters. The currents shown are only the average current in the I²C pullup resistors, which are assumed to be 10 kΩ with VCC at 3 V. Both the MCU and the AMX8XX will draw additional current during any I²C transaction which will be in addition to the current shown in the table. This shows that if frequent burst reads are required, the I²C frequency must be much higher than 10 kHz in order to minimize power dissipation which will therefore produce insignificant time loss.

Table 5-3: Burst Read Power Requirements

| I ² C Freq | Xfer Length (ms) | Current at Burst Frequency (nA) | | | |
|-----------------------|------------------|---------------------------------|-------|-------|----------|
| | | 10/sec | 1/sec | 1/min | 1/15 min |
| 10000 | 10.4765 | 31430 | 3143 | 52 | 3 |
| 20000 | 5.2667 | 15800 | 1580 | 26 | 2 |
| 30000 | 3.5095 | 10529 | 1053 | 18 | 1 |
| 40000 | 2.6565 | 7970 | 797 | 13 | 1 |
| 50000 | 2.13625 | 6409 | 641 | 11 | 1 |
| 75000 | 1.4508 | 4352 | 435 | 7 | 0 |
| 100000 | 1.0616 | 3185 | 318 | 5 | 0 |

SECTION

6

Delay Between Read Address and Data

A question has been asked about the case where a delay is inserted between the I²C read address transaction and the burst read data, as shown in Figure 6-1. If this sequence occurs, the Delay value is added to the transfer length shown in Table 5-3 on page 16 and changes the effective I²C clock frequency. For example, an I²C clock frequency of 50 kHz with a 3 ms delay inserted in every burst read is equivalent to a 20 kHz clock frequency. This would increase both the error frequency from Table 5-1 on page 15 and the average power from Table 5-3 on page 16. However, this stretching of SCL can only be caused by either the I²C Master (the MCU) or the accessed slave (the AMX8XX). There is no reason that a Master would ever stretch SCL in this way, since it would slow down the bus and result in increased power dissipation. The AMX8XX never stretches SCL, so this sequence should never occur.

Figure 6-1: Read Transactions Delay

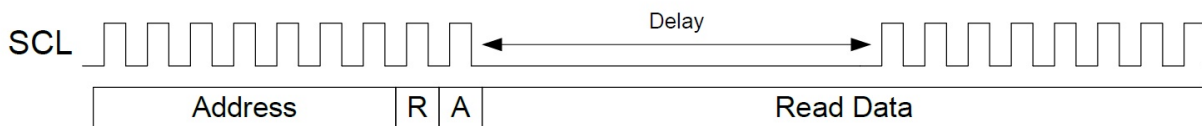



© 2023 Ambiq Micro, Inc. All rights reserved.

6500 River Place Boulevard, Building 7, Suite 200, Austin, TX 78730

www.ambiq.com

sales@ambiq.com

+1 (512) 879-2850

A-RTCX85-ANGA03EN v2.0

January 2023